

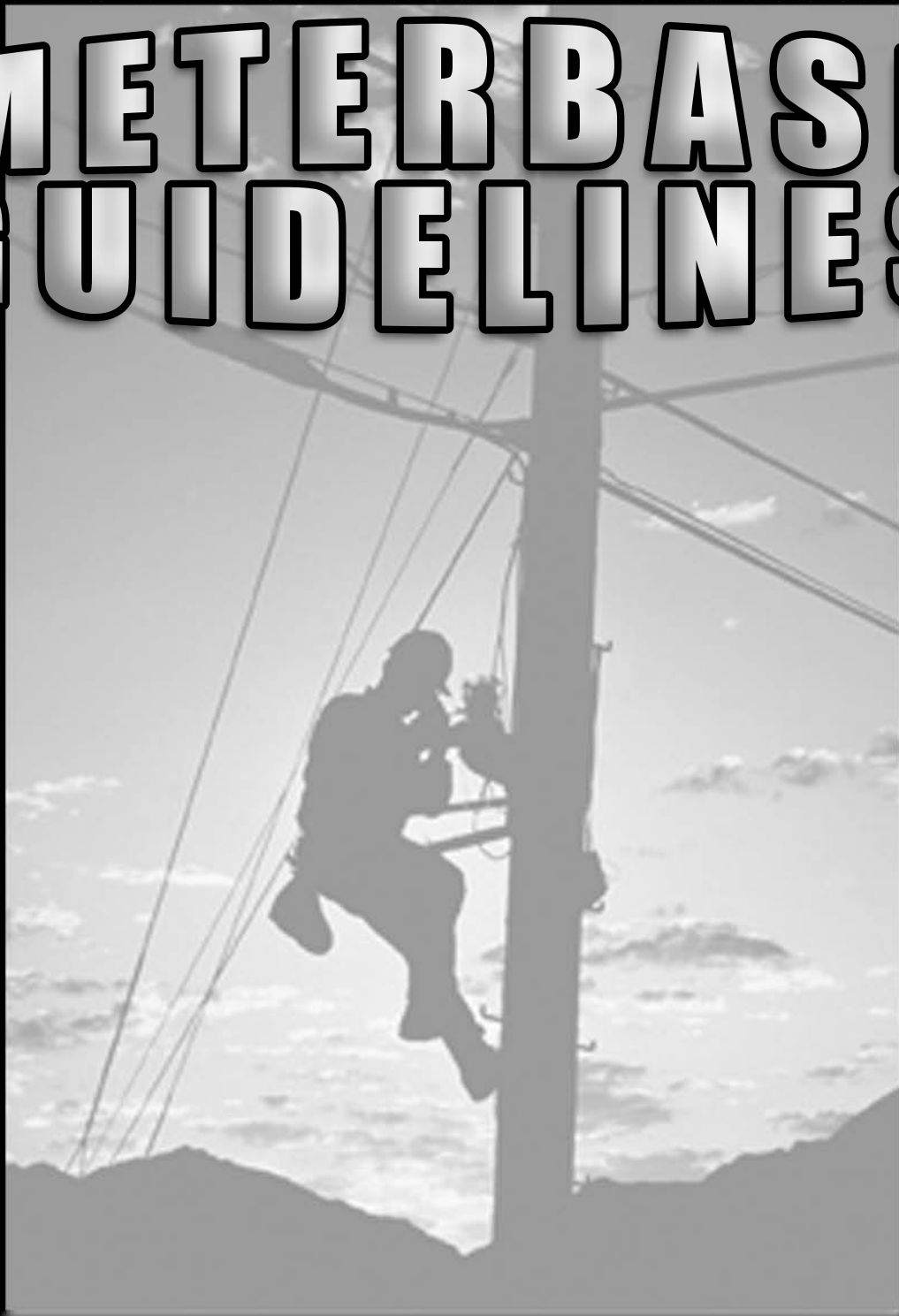

COPPER VALLEY ELECTRIC ASSOCIATION, INC.

METERBASE GUIDELINES



OVERHEAD TO GABLE END

New Service Installation Steps:

This is a step-by-step guide to the process CVEA will take to fulfill your service installation request. Please review the steps, familiarize yourself with the key milestones of the process, and identify common issues that can arise. We look forward to providing you with a new service. If you have any questions, concerns, or comments about the process, please call the CVEA Glennallen office at (907) 822-3211 or the Valdez office at (907) 835-4301.

Step #1: Apply for Service

Please stop by one of CVEA's office buildings to complete an application for service. The applications can also be found at www.cvea.org. Please be sure to fill this document out as completely and specifically as possible to prevent any future delays. The Customer Service Representative (CSR) will put you in contact with the Field Services Representative (FSR) in order to meet you for a site visit.

Step #2: Complete a Site Visit

Once an application is complete, your request is forwarded directly to the Engineering Department. The FSR will set up a time to perform a site visit, usually within one week. The purpose of the visit will be to determine the best location for your meterbase, the most efficient direction to route the service, whether a standard offering is applicable, and where to set electrical equipment (i.e. poles, transformers, pedestals). It will also be determined whether locates from other utilities will be required. After the visit, the Engineering Department will provide you with an estimate within one to three days. If accepted, the estimate must be signed and returned to CVEA accompanied by payment or a loan application.

Step #3: Gathering Necessities

After the site visit, the FSR may need additional information from you. Additional fees, city inspections, and right-of-way easements may be requested. Also, permits may be needed from adjoining property owners, highway departments, or other entities. We will contact you by phone if more information is needed. Your service request cannot move beyond this step until you have installed your meterbase correctly and the requested information and payment have been received.

If a delay seems apparent in getting your service, please call the FSR for an update. When this step is completed, your work order gets forwarded to the Operations Manager.

Step #4: Installation of Service

The Operations Manager will issue your work order to a line crew that will install the service. Then the Operations Manager will contact you to schedule a time for construction. The time it takes to complete this step can vary. The construction will include all the equipment and structures presented to you by the FSR in step 2, with the possibility of some minor changes. The line crew will complete everything up to CVEA's side of the meterbase, but are not permitted to do any work to your side of the meterbase.

Common Slow Downs:

1. **Alaskan Weather** can hamper, or even cancel, the construction process. It is important to contact CVEA about a new service long before the winter months. We will do our best to give you an estimated date of completion. The date of completion is always subject to change.
2. Be sure to have your **meterbase correctly installed** prior to the construction date.
3. If in Valdez, be sure that the city **inspects** your meterbase prior to the construction date.
4. **Right-of-way easements** are often required in order to begin construction. This will require you to provide a recorded deed to the Engineering Department. After the information is received, CVEA will require you to sign the easement in the presence of a notary. Notaries are available, free of charge, at both CVEA offices (call in advance to make sure a notary is available).
5. Make sure that your application for service is completed with current and accurate **contact information**. Communication is essential in assuring the process moves forward.

Other Possible Steps:

1. If you are requesting **temporary service for new construction**, your lot needs to be cleared and the structures need to be clearly staked. Also, the temporary meterbase will need to be properly installed and possibly inspected. A CVEA representative will perform a site visit before the temporary service is activated.
2. If you are requesting to change from an existing **temporary service to a permanent service** you should immediately have all inspections completed. A site visit will be required by CVEA to approve meterbase location. Be sure to do this step before pouring any concrete between the temporary service and the permanent service areas. A new application is not required, but you should notify CVEA when the work is ready to be completed.
3. **Mobile home lots** should be graded and the mobile home set up before installation of service. If this is not possible then the location should be staked off, indicating the four corners of the structure. You should also indicate where you want the meter post to be located. The meter post must meet CVEA specifications. In some instances, double wide mobile homes may have the meterbase installed directly to the home. To inquire about service to a mobile home, please contact the Engineering Department.

Notes:

1. Meter locations need to be approved by CVEA's Engineering Department.
2. In addition to CVEA's requirements, the installation must meet all current National Electric Code requirements and any other state or local codes.

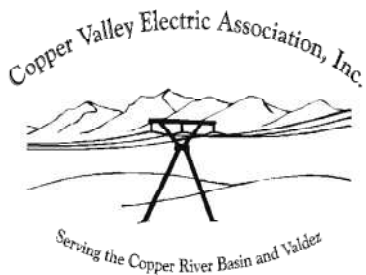

Copper Valley Electric Association, Inc.
P.O. Box 927 Valdez, AK 99686
907-835-4301 (Phone) 907-835-4328 (Fax)
Engineering Department

1. Remove the knockout on the top left hand side and the small knockout on the bottom right side of the meter base. (see wiring diagram)
2. Place the raintight hub for 2" conduit over the top knockout hole and secure it with the four screws provided.
3. Thread the riser into the raintight hub and tighten to a snug fit.
4. Snap the breaker switch into the breaker bus bar, see wiring diagram for positioning.
5. Complete the meter base wiring as per the meter base wiring diagram.
6. Install the weather head on top of the riser by inserting the conductors through the holes on the inside of the weather head, then sliding the weather head on to the top of the conduit riser, now tighten down the clamp on the weather head to secure.
7. Install the assembled meter base to the house with lag screws.
8. Secure the conduit riser to the house with 2" conduit clamps with a spacer between conduit and house to assure a snug fit.
9. Install the ground rods, both must be at least 2' from the edge of the house and separated by no less than 8'. Connect ground wire per wiring diagram.

SINGLE-PHASE SERVICE 200 AMPS or Less
(120/240 V)

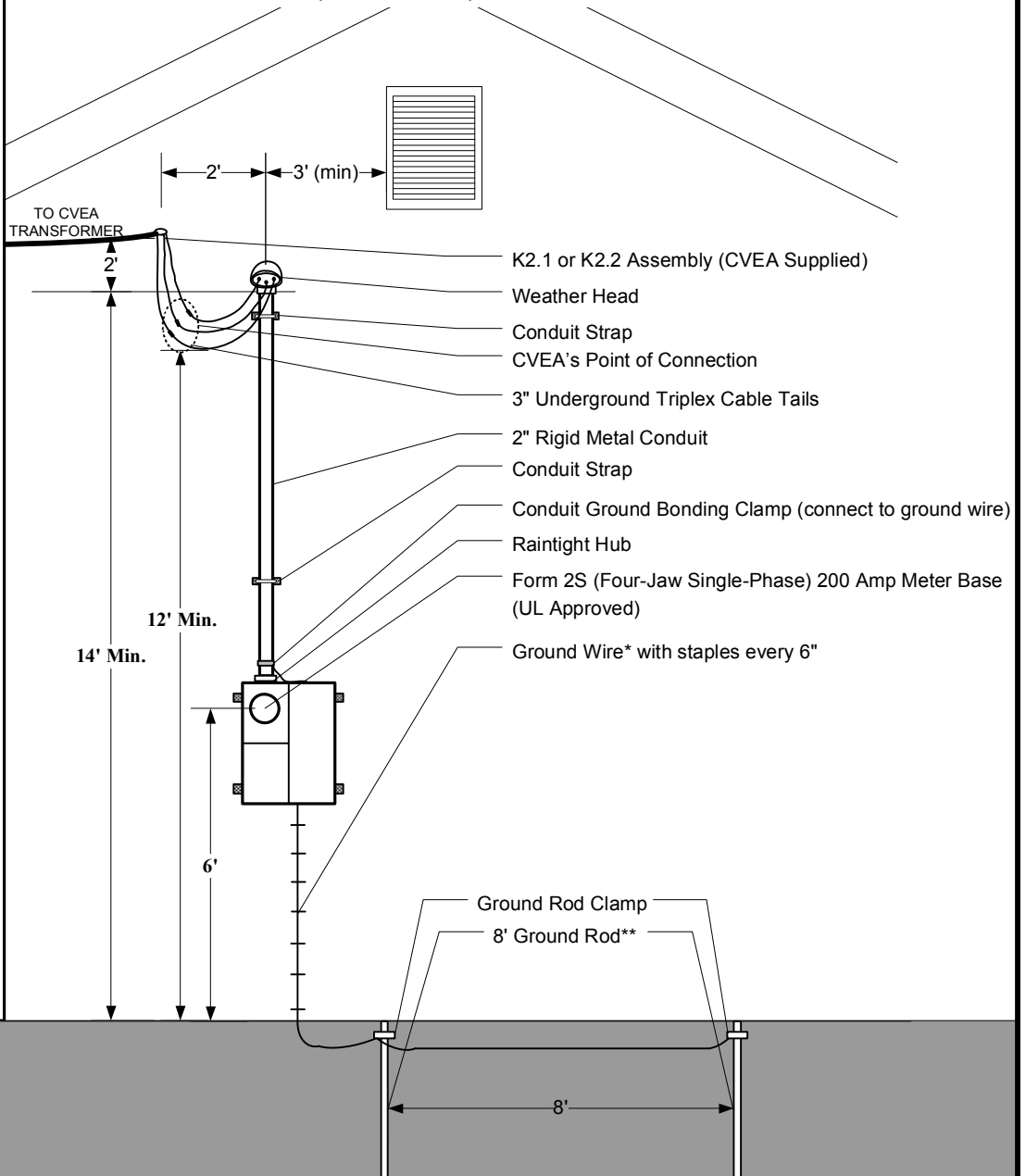

***Size of Ground Wire shall be #6 A.W.G. solid copper (minimum).**
****Size of Ground Rods shall be 5/8" x 8' (minimum). Top of Ground Rod shall be flush with ground and no less than 2' from the closest edge of structure or foundation.**
All service drop conductors shall be no less than 3' from any door, opening window or other opening.

DIAGRAM NOT TO SCALE
OVERHEAD SERVICE TO HOUSE GABLE END DIMENSIONAL DIAGRAM AND ASSEMBLY INSTRUCTIONS
REVISION 11/15/2007

METER BASE WIRING DIAGRAM – METER BASE ASSEMBLY OVERHEAD SERVICE TO HOUSE

Copper Valley Electric Association, Inc. ~ P.O. Box 927 Valdez, AK 99686 ~ 907-835-4301 (Phone) 907-835-4328 (Fax) ~ Engineering Department

Note: Install the weather head on top of the riser after the conductors have been installed in the riser, and the meter base. Conductors to be installed in the meter base by consumer.

To Install the conductors to the Meter Base Lugs:

1. Run the three conductors down the riser into the meter base.
2. Cut and remove the polyethylene conductor coating back 1" from the ends of the three conductors.
3. Apply a coating of corrosion inhibitor to the bare aluminum conductors.
4. Take the black conductors and place them into the meter base lugs and tighten down.
5. Take the white (or black with white stripe) conductor and place it in the neutral bus bar and tighten them down.

Note: The consumer's conductor's may be run in after the CVEA service is installed. Services in Valdez shall be inspected by the City prior to CVEA's service installation. Service entrance cables from meter to consumer's breaker panel must be type SE cable or must be run in conduit.

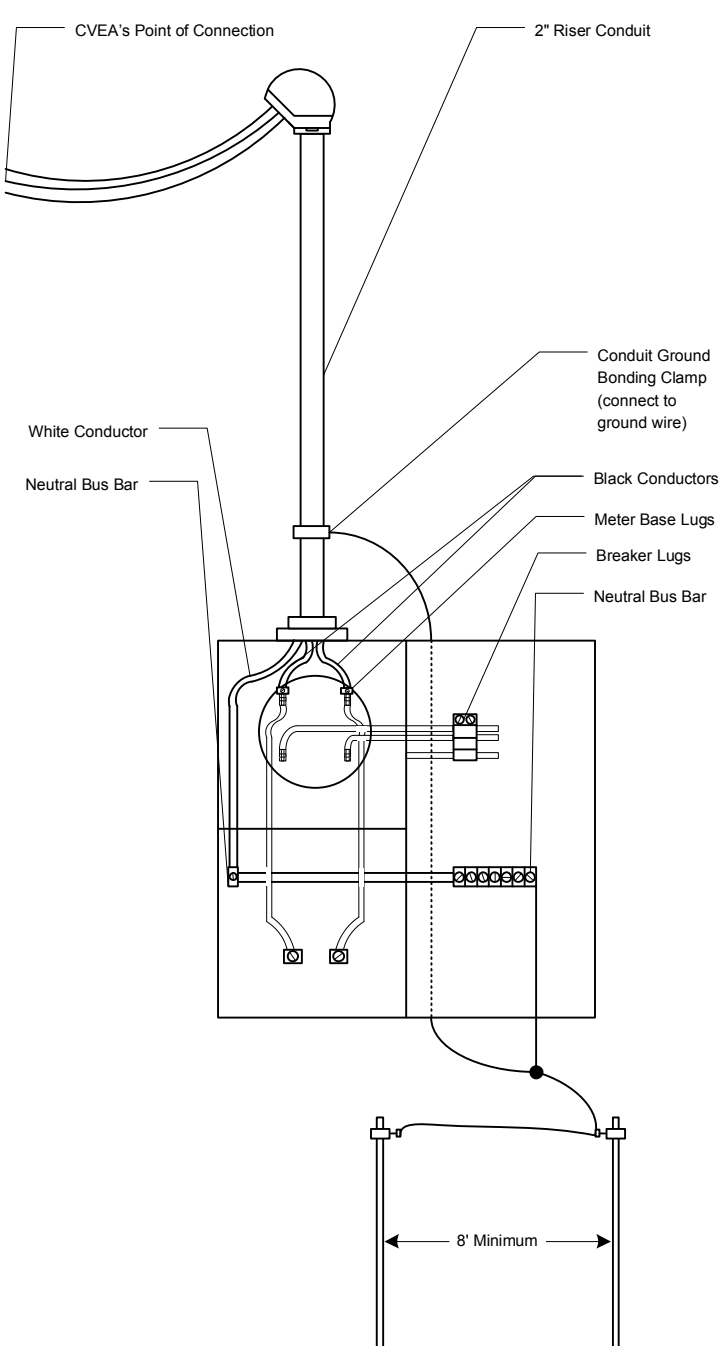

To Install the conductors to the Breaker Switch on the consumer's side of the Meter Base:

1. Run the three conductors from the consumer's residential breaker box into meter base.
2. Cut and remove the polyethylene conductor coating back 1" from the ends of the three conductors.
3. Apply a coating of corrosion inhibitor to the bare aluminum conductors.
4. Take the 2 black conductors and place them in the breaker lugs and tighten them down.
5. Take the white (or black and white striped) conductor and place it in the neutral bus bar and tighten them down.

The following steps are to be done **AFTER** the meter base is installed on the house:









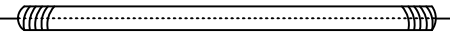
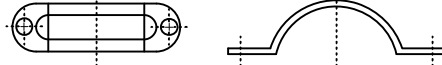
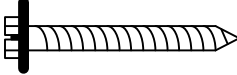

6. Insert the bare copper wire through the small knockout hole in the bottom of the consumer side of the meter base. Then insert the bare copper ground wire into the lug on the neutral bus bar and tighten down the lug. Next, insert the bare copper ground wire into the the ground wire clamp and tighten down. Leave enough slack to be able to staple the ground wire to the house. (SEE METER BASE ASSEMBLY INSTRUCTIONS).
7. Continue the ground wire from the first ground rod to the second ground rod placed a minimum eight feet away.
8. Connect the conduit ground bonding clamp to the ground system using ground wire.

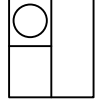
OVERHEAD CONSTRUCTION
GABLE END OF HOUSE
METER WIRING GUIDE
REVISED 11-15-2007

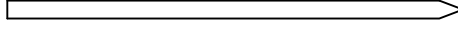
Parts List For Overhead Service To Gable End of House

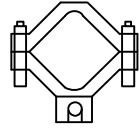
NOTE: Parts list is provided as a consumer aid to identify required parts.

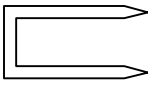
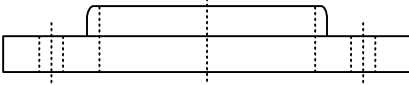
Copper Valley Electric Association, Inc. ~ P.O. Box 927 Valdez, AK 99686 ~ 907-835-4301 (Phone) 907-835-4328 (Fax) ~ Engineering Department

Check if needed	Cost	Item	Description
1. _____ (1)	\$ _____		Weather Head for 2" galvanized rigid steel
2. _____ (1)	\$ _____		10' of 2" rigid steel galvanized
3. _____ (4)	\$ _____		2" Conduit Clamps
4. _____ (11)	\$ _____		Lag Screw for conduit clamps / meter base
5. _____ (1)	\$ _____		14' URD Triplex Conductor (See conductor sizes listed below)
6. _____ (1)	\$ _____		U.L. Approved Meter Base
7. _____ (2)	\$ _____		Main Breaker sized for proper consumer service cable (See conductor sizes listed below)
8. _____ (2)	\$ _____		5/8" x 8' Copper Clad Steel Ground Rod
9. _____ (2)	\$ _____		Ground Rod Clamp
10. _____ (1)	\$ _____		Conduit Ground Bonding Clamp
11. _____ (1)	\$ _____		20' #4 Bare Solid Copper Ground Wire
12. _____ (10)	\$ _____		Ground Wire Staples
13. _____ (1)	\$ _____		Raintight Hub for 2" Conduit
14. _____ (1)	\$ _____		Tube of Corrosion Inhibitor

FEEDER AND SERVICE ENTRANCE CONDUCTOR SIZES

SERVICE AMPACITY (Breaker Size)	ALUMINUM (AWG)	COPPER (AWG)
100 Amp	2	4
125 Amp	1/0	2
175 Amp	3/0	1/0
200 Amp	4/0	2/0
400 Amp or Greater	(See Engineering Dept.)	(See Engineering Dept.)

Updated
11-15-2007